



Compliance Certified  
EBWA Challenge Test 2007



# EMax

Europe's Best Selling Watercooler

# 1. Introduction

The EMax is Europe's best selling watercooler - with over half a million units sold since its launch in 2000.

This is the cooler that cemented Ebac as the market leader in the watercooler manufacturing industry - renowned for its strength and durability, the EMax can be sanitised in seconds with our patented WaterTrail™ system and features our award-winning Hot Tank that is 30 times more efficient than competitor models.

Available in a range of colours, the EMax provides a fantastic all-round solution for customers looking for an established fleet cooler built on quality, value and reliability.

## Contents

### 1. EMax Introduction

### 2. WaterTrail™

- Sanitise 40% More Coolers
- 100% Sanitisation

### 3. Hot Tank

- Unrivalled Energy Efficiency
- Europe's Best Selling Watercooler

### 4. Good Looks That Last

- Robust Construction
- Changeable Fascias

### 5. Product Features

- No Leak Manifold
- Changeable Fascias
- Patented Label Splitter
- Watertrail™ for 100% Sanitisation
- Twin Integral Cup Holder
- Easily Reconfigured On-Site
- Re-inforced Bottle Column
- Built In Wheels

### 6. Technical Specification Comparison



“With its impeccable reliability, robust design and quality build, the EMax is a great all round offering that represents fantastic value for money”

John Elliott MBE, Chairman, Ebac Group Ltd

## 2. WaterTrail™

Developed in 1994, the WaterTrail™ is now the most popular method of sanitisation in Europe. All water contact parts are simply replaced – not cleaned – meaning 100% sanitisation takes a matter of just seconds.

The WaterTrail™ saves you both time and money as more coolers can be sanitised per day, and staff do not need complex training.

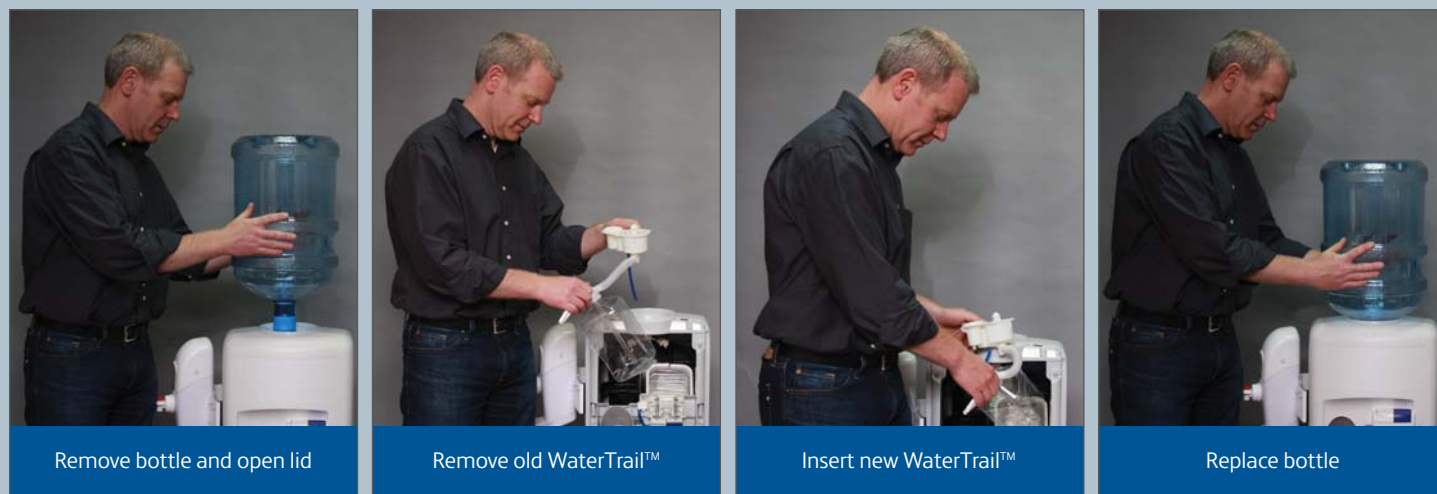

### Sanitise 40% More Coolers Per Day

Unlike sanitisation which requires time consuming processes that don't always result in a fully cleaned and disinfected watercooler, the WaterTrail™ can be easily changed, even by a child, in less than 60 seconds. Normal methods of sanitisation take between 20 minutes (On-site Chemical) and 5 minutes (Steam) (see Fig 1.1). Not only do these methods take longer, but they are also considerably more complex (with a greater margin for error) and require extensive staff training and rigorous quality control systems.

With the WaterTrail™, the old unit is removed from the cooler, and the new one is inserted into place as shown in the images above.

This means it's easy for staff to do it right first time, every time - with minimal training and minimum increase in his or her normal duties.

Fig 1.1 Sanitisation Method Time Comparisons

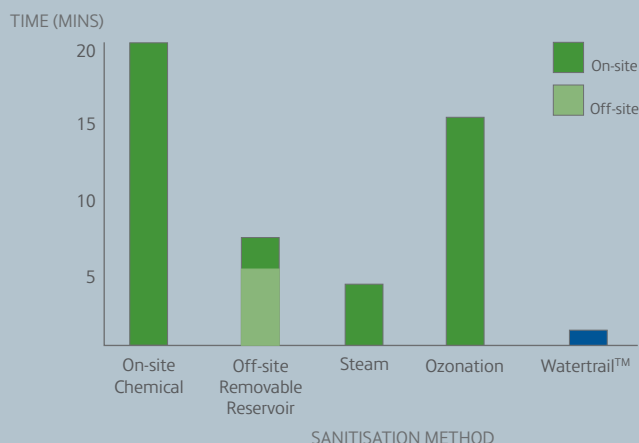

### 100% Sanitisation

Our removable WaterTrail™ replaces all water contact parts, and is the only system available to offer true 100% sanitisation every time.

Steam cleaning and Ozonation methods of sanitisation do not clean the watercooler - they only disinfect it - although they do kill the bacteria, they do not remove the biofilm. Therefore these methods do not comply with BWCA regulations which state that the cooler must be cleaned, not just disinfected - making coolers based on these methods of sanitisation non-compliant with the BWCA.

The WaterTrail™ is fully compliant with the BWCA as all water contact parts are replaced.

Traditional reservoirs also have an additional risk, as the way they are designed means a pocket of air sits above the water (see Fig 1.2). This creates more favourable conditions for bacterial growth when compared to the WaterTrail™ in which water does not come into contact with air at all.

Fig 1.2 Traditional Reservoir Air Contact

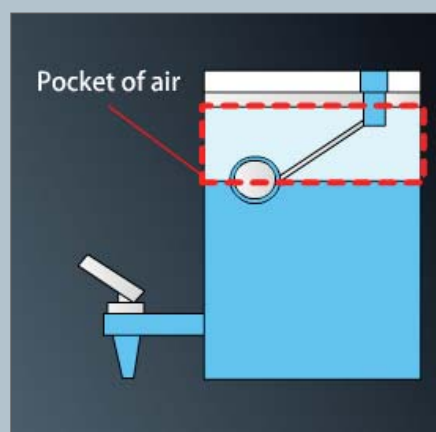

### 3. Hot Tank

Our Energy Efficient Hot Tank was the winner of the 2007 Cooler & Vending Awards 'Best Sustainability Initiative' and the Silver Award Winner for the EBWA 'Best Environmental Initiative' award.

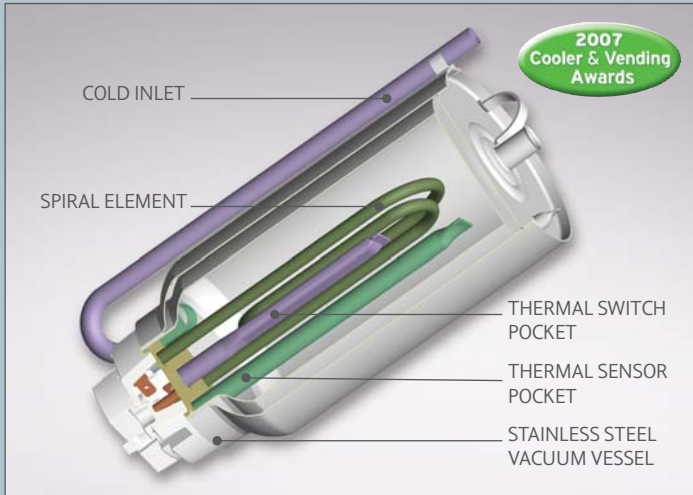

#### Unrivalled Energy Efficiency

Energy efficiency is becoming of increasing importance to watercooler customers - in a recent study we found that 76% of facility managers would be 'much more likely' to purchase a unit that was more energy efficient than competitors.

Unlike competitor models, our industry award winning Hot Tank in our EMax works like a vacuum flask and features an extra layer of insulation to ensure than it retains its heat - it is therefore heated less frequently, and as a result is 30 times more energy efficient than other Hot Tanks.

Customers will save around £32 /€40 per cooler each year on running costs - so a medium size business with 5 coolers will save over £150 /€190 each year. As well as financial savings, customers will also be reducing their Carbon Footprint - an increasingly important fact.

Fig 1.3 Hot Tank Energy Consumption

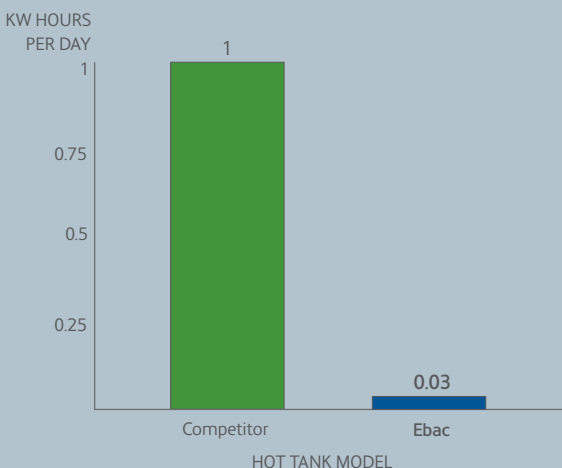

When you offer your customers the EMax - you not are not only offering an established cooler built on reliability and quality, but the peace of mind and fantastic reputation that comes with Europe's best selling Watercooler.



#### Europe's Best Selling Watercooler

Zenith (2007) predicts that over the next 5 years that UK Bottled Watercooler sales will continue to increase from 490,000 units in 2007 to 515,000 units in 2012 (See Fig1.4). With this in mind, the importance of offering customers an established cooler that is proven in the market can be key to success.

Ebac did not become market leaders overnight - and the EMax has played a large role in establishing Ebac as suppliers of the best watercoolers in the world since it launched. With sales now totalling over 500,000 units (and still growing), the EMax is currently in use in every single EU country, and many more besides.

The reassurance to customers that comes with being able to offer Europe's best selling watercooler is considerable - which is why 84% of our customers choose to include the EMax in their watercooler portfolio.

Fig 1.4 Forecast Total UK Cooler Numbers, 2007 - 2012

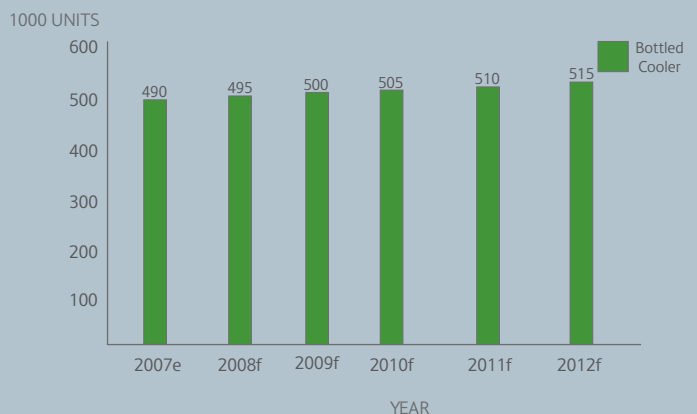

Source: Zenith (2007)



## 4. Good Looks That Last

Combining good looks with impeccable reliability – the EMax features stylish curves to fit into the modern office environment and is constructed from ultra-durable ABS polymer to ensure it withstands many years of use and keeps repair and replacement costs down.



### Robust Construction

Customers are increasingly demanding a Watercooler that fits in with their modern office, and the EMax is the perfect cooler to meet their requirements. During construction we use 3 or 4 times more material than we need to at weak points to ensure the watercooler withstands years and years of constant use.

Designed to be stylish, modern and practical - the EMax is built from ultra durable ABS Polymer. This exceptional durability - four chassis can support the weight of a vehicle - means that the cooler will take what ever your worst customer throws at it - it will never rust, and will therefore save you time and money in repair and replacement costs.

To offer your customer maximum choice and reduce the costs associated with cooler damage, the EMax is available with a selection of 5 different fascias.



### Changeable Fascias

The EMax also features a choice of 5 changeable fascias, meaning you can win more customers by offering a customised cooler to suit their own office, and you will also save money on replacements as damaged fascias can be easily interchanged without having to replace the entire cooler.

The EMax is available with the following fascias:

- Blue
- Green
- Orange
- Purple
- White

Fig 1.5 The EMax's changeable fascias.





## 5. Product Features

Renowned for its strength and durability, the EMax can be sanitised in seconds with our patented WaterTrail™ system and features our award-winning Hot Tank that is 30 times more efficient than competitor models.

### No Leak Manifold

Ensures drips from the bottle cap do not contaminate the water reservoir or cause leaks.

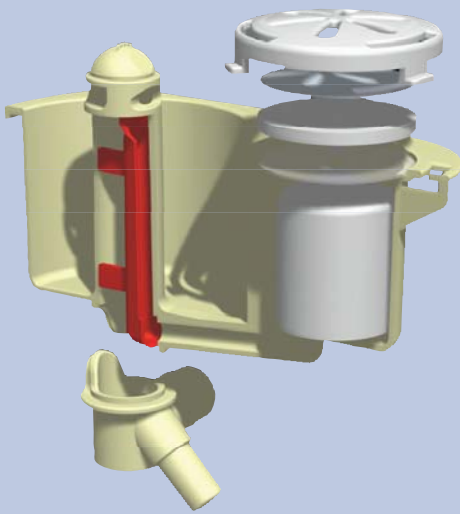

### Changeable Fascias

A choice of 5 changeable fascias mean that you can offer customers maximum choice and flexibility.



### Patented Label Splitter

With our Hedgehog Spike the water bottle label is pierced but never dislodged - this ensures that labels are never pushed up into the bottle.

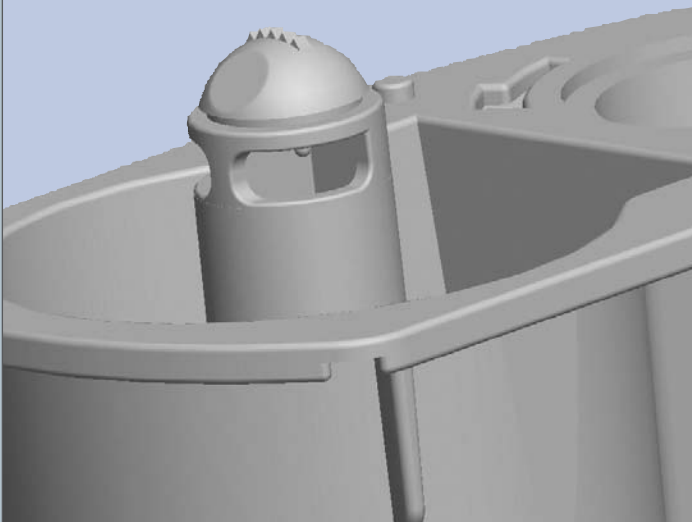

### WaterTrail™ for 100% Sanitisation

Using our patented WaterTrail™ system, all water contact parts are simply replaced, not cleaned - meaning you have 100% sanitisation in a matter of seconds.

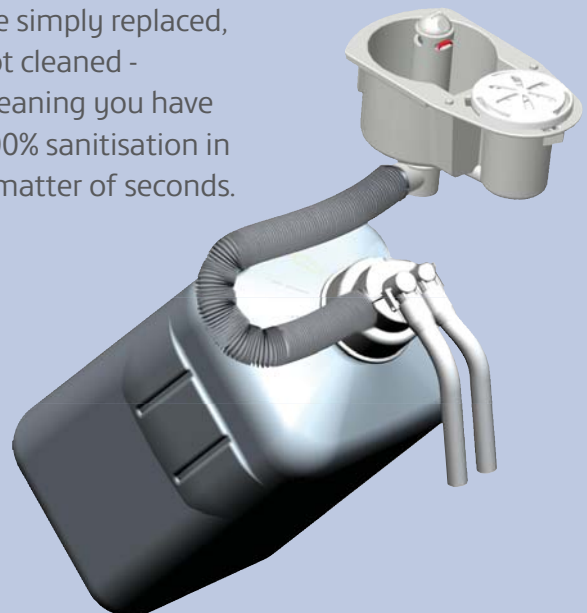



### Twin Integral Cup Holder

Cups are positioned upside down preventing contamination, with visual indication for low cup supply.

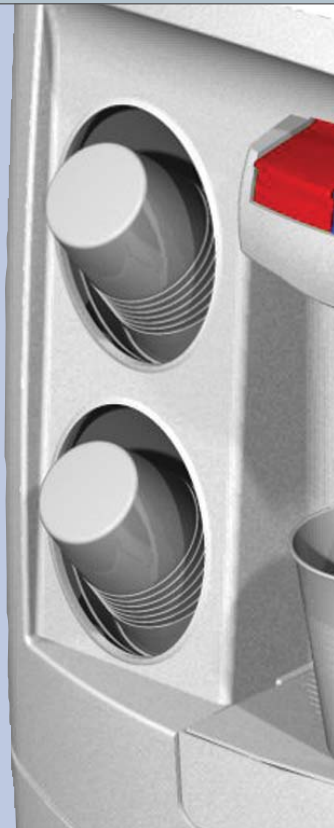

### Easily Reconfigured On-Site

Change configuration efficiently from 'Cook n Cold' to 'Hot n Cold' to offer maximum choice to your customers.



### Re-inforced Bottle Column

Loading full bottles onto a water cooler is a frequent cause of cooler damage - which is why our EMax has a reinforced column to ensure that no damage can be caused to the cooler even over many years of use.

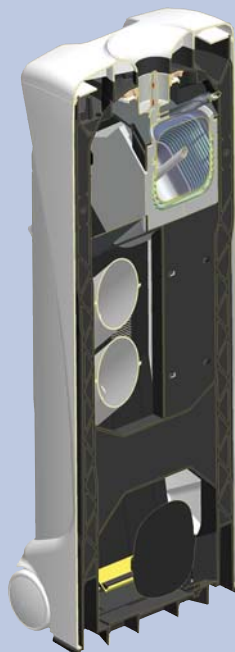

### Built In Wheels

Means that the EMax can easily be transported from one location to another safely, and with no heavy lifting required.



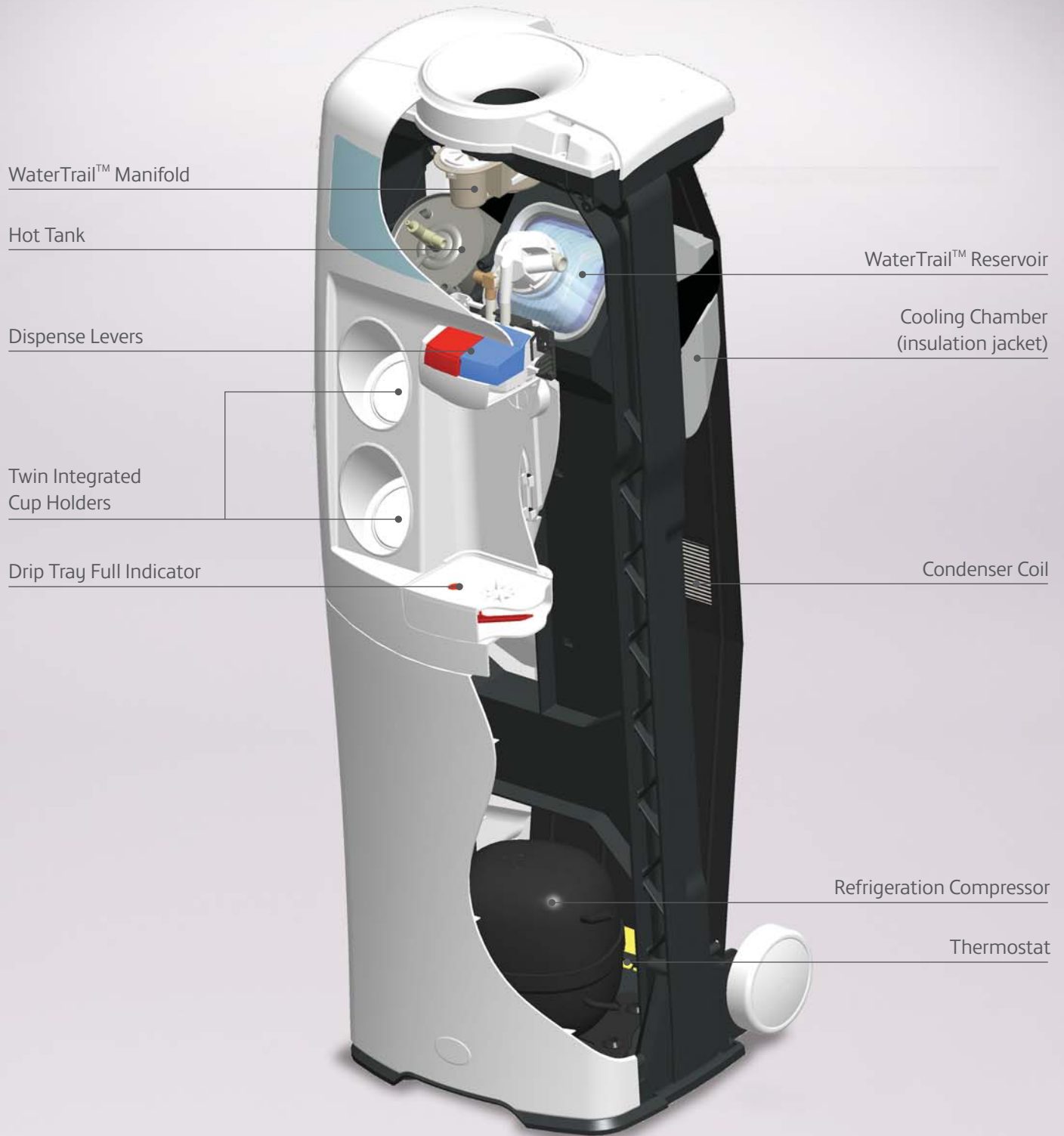

## 6. Technical Specification Comparison

The following table compares all Ebac Watercooler models to help you understand the differences and similarities between each cooler.

	SlimCool Filter	SlimCool Bottled	EMax	EMax POU	FMax	FMax POU
<b>Specifications</b>						
Height (cm)	95.5	95.5	100	100	110	112
Width (cm)	20	20	33	33	26	26
Depth (cm)	20	20	33	33	39	39
Weight (kg)	13	13	17.5	17.5	20	23
Approvals - CE, CB	✓	✓	✓	✓	✓	CE
Refrigeration Type	Electronic	Electronic	R134A	R134A	R134A	R134A
Air Filtration (Microns)	-	0.5	0.5	0.5	0.5	-
Water Filter Type	Brita Maxtra	-	-	Carbon block	-	Carbon block
Water Filter Life (weeks)	4	-	-	26	-	26
Hot Tank Energy Consumption (standby) (KW/day)	-	-	0.03	0.03	0.03	0.03
Hot Water Temperature (°C)	-	-	86°C / 94°C	86°C / 94°C	86°C / 94°C	86°C / 94°C
Hot Tank Heat Up Time (minutes)	-	-	15	15	15	15
<b>Sanitisation Features</b>						
WaterTrail™ Sanitisation System	✓	✓	✓	✓	✓	-
Cassette WaterTrail™ Sanitisation System	✓	✓	-	-	✓	-
Duplex Dispense Nozzle	✓	✓	-	-	✓	✓
Direct Dispense System	-	-	-	-	-	✓
<b>Functional Features</b>						
Adjustable Drip Tray	✓	✓	-	-	-	-
Drip Tray Evaporation	-	-	-	-	✓	✓
Built In Wheels	-	-	✓	✓	✓	✓
Integrated Cup Dispenser	-	-	✓	✓	✓	✓
Height Adjustable Feet	-	-	✓	✓	-	-
Quick Change Side Panels	✓	✓	-	-	✓	✓
High Dispense Point	✓	✓	-	-	✓	✓
Hedgehog Spike	-	✓	✓	-	✓	-
<b>Additional Features</b>						
Burst Rate (no. of consecutive chilled cups)	12	12	10	10	14	20
Hot Tank Burst Rate (no. of consecutive hot cups)	-	-	6	6	6	6
No Leak Manifold	-	✓	✓	-	✓	-
ABS Polymer Body	✓	✓	✓	✓	✓	✓



Ebac Limited, St Helen Trading Estate, Bishop Auckland, County Durham, DL14 9AL

Tel: 01388 605061 ext. 424 or 432    Email: [watercooler@ebac.com](mailto:watercooler@ebac.com)  
[www.ebacwatercoolers.com](http://www.ebacwatercoolers.com)

Details are correct at time of going to press. All specifications and features are subject to change at Ebac's discretion.